

Special Installation: Limiting Island Movement

ROCKFON Islands

In some installations, limiting the movement of the ROCKFON Islands may be necessary due to specific field conditions. The following is a guide to a ROCKFON approved method for restraining the potential movement by utilizing the DAB bracket along with conventional industry practices.

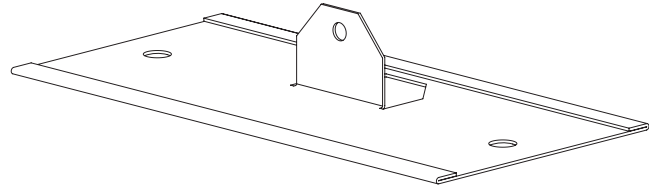

Applicable ROCKFON Islands

4'x4', 4'x6' and 4'x8' (nominal sizing)

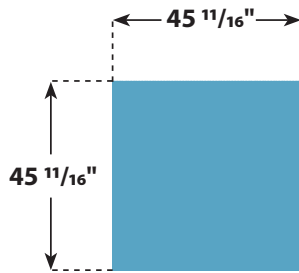

Item #8100
4' x 4' nominal

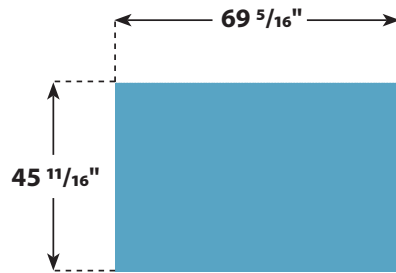

Item #8125
4' x 6' nominal

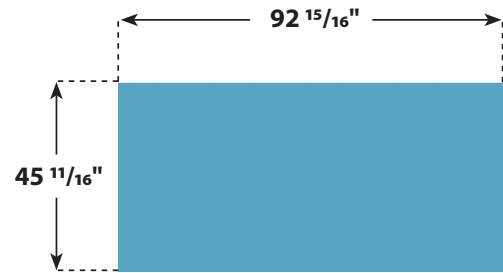

Item #8150
4' x 8' nominal

Installation

Follow the ROCKFON Stonewool Islands Installation guide for suspending the islands. The islands must be level and installed with four hanging points on the 4' island and six hanging points on both the 6' and 8' versions.

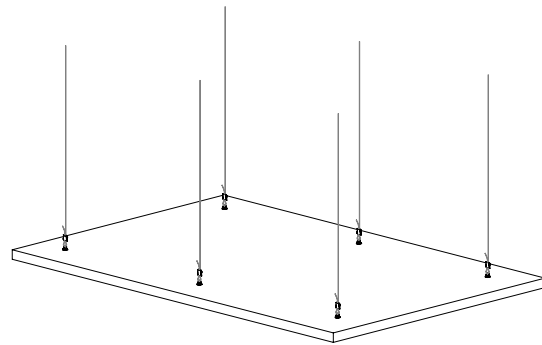

DAB: 448.992

It is recommended to install the double anchor bracket on the 4' and 6' islands to increase the anchorage. See the Double Anchor Bracket (DAB): ROCKFON Island Accessory Technical Note for further installation guidelines.

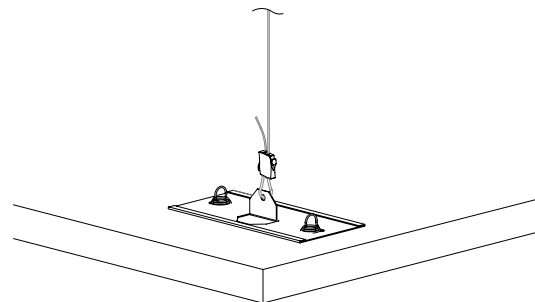

Special Installation: Limiting Island Movement

Restraining ROCKFON Islands

Install a 448.992 DAB in the center of the panel, aligning the long edge of the DAB with the long edge of the panel. Finding the center of the panel is easily achieved by using a straight edge from opposite corners as shown below. The back surface of the DAB, or the entire area on the back of the panel where the DAB will be adhered, must be coated with adhesive prior to installation. Press the bracket firmly down insuring even distribution of the adhesive. Install two spiral anchors through the holes located near the ends of the DAB. The spiral anchors will hold the bracket in place while the adhesive cures. Follow the adhesive manufacturer's directions for proper installation.

ROCKFON recommended adhesives:

- Sikabond® Construction Adhesive
- Titebond® GREENchoice™ Acoustical Ceiling Tile Adhesive

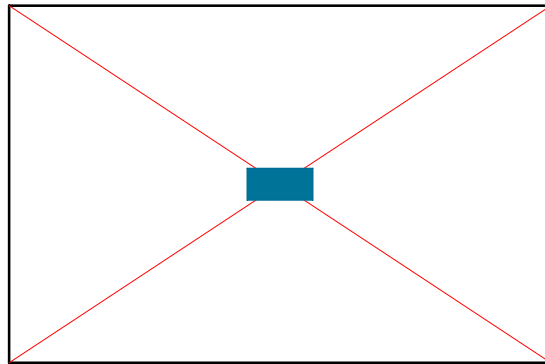

Down Post Installation Details

Proper sizing of the down post must be determined by the engineer of record. See the ROCKFON Seismic Guide for more information about down post sizing. The down post needs to be anchored to the deck or acceptable structural member per code. Anchor the down post to the DAB with QTY:3 #8 sharp point metal screws through the tab of the DAB and into the stud. Drill two holes through the tab of the DAB and stud. These holes are the attachment points for the splay wires. Install splay wires as defined by ASTM E580, utilizing 12 gauge wire. It's important to note that depending on the drop of the island from the deck, the splay wires may be visible outside of the area of the island and could affect the look of the completed installation.

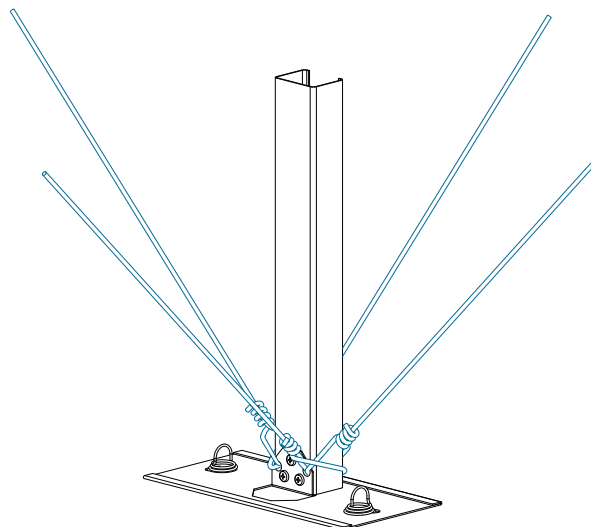

Special Installation: Limiting Island Movement

Splay Wires Continued:

Splay wire layout, suspension wires shortened for clarity of image.

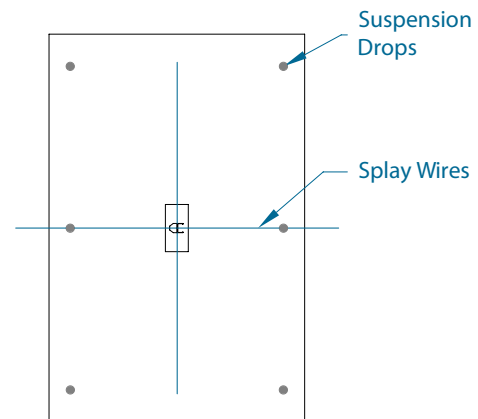
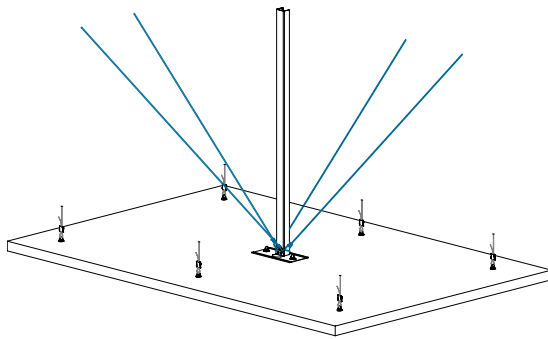

Controlling Torsion Around the Down Post

In addition to the down post, additional splay wires are required to limit the rotational movement of the island. Install crossing wires at both ends of the islands. Crossing wires shall be 45° or less to the ceiling plane as defined by code. This is done by installing one end of the 12 gauge hanger wire to the deck near the original suspension point and tying the wire to the adjacent (short side) spiral anchor. This is required on all four corners of the island.

Once complete there will be a total of 4 splay wires on the down post and 4 wires restraining the ends of the panel. These wires are in addition to the original wires or aviation drops used to suspend the island.

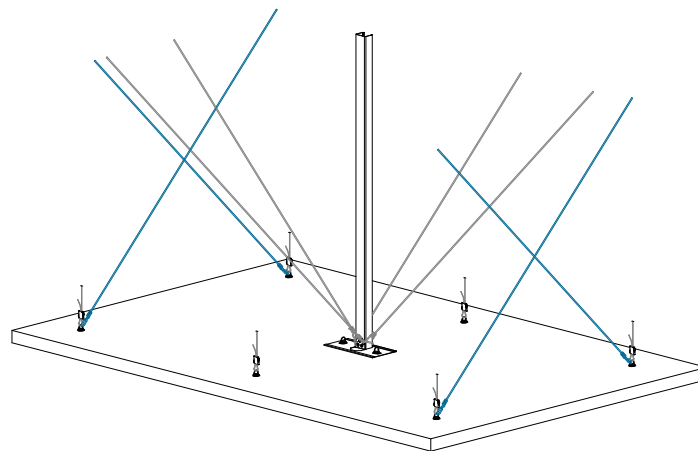

Have questions?

Contact the ROCKFON Technical Services Team by calling 800-323-7164, prompt 3 and we can provide assistance on your project.



ROCKFON 4849 SOUTH AUSTIN AVE., CHICAGO, IL 60638 / USA and Canada: 800-323-7164 / Fax: 800-222-3744 / rockfon.com